

K

A

α

TYPEFACE

by

S I M O N

S L E E G E R S

Y

A

X

• CONSTRUCTION •

Q

• CONSTRUCTION •

t

f

travesti
fokuş
yapmak

inşaat
inşaatçı
çalışmak

g

Hand-drawn sketches and letters on the right page of the notebook, including a large 'R', 'W', 'Z', 'K', and various geometric shapes and lines.

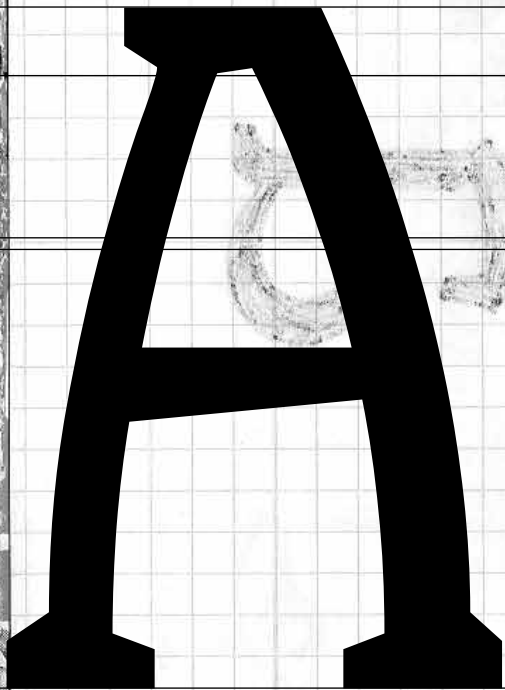

A large, bold, black serif letter 'A' is centered on a grid background. Behind it, there are faint pencil sketches of the letter, showing its construction and proportions.

• CONSTRUCTION •

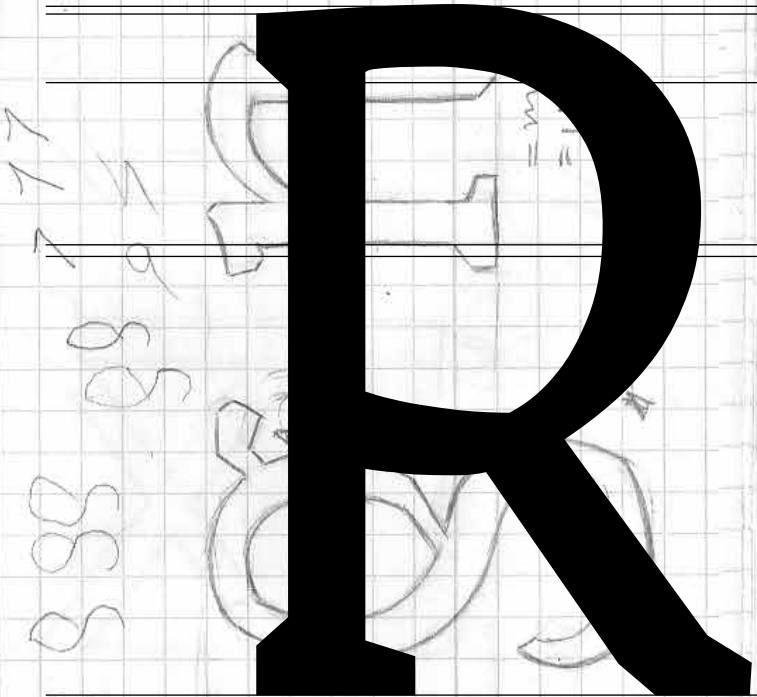

A large, bold, black serif letter 'R' is centered on a grid background. The page is filled with various pencil sketches and annotations, including a large 'R' with a vertical line through it, a smaller 'R' with a vertical line through it, and several 'S' characters. There are also some numbers and other markings scattered around the letter.

• CONSTRUCTION •

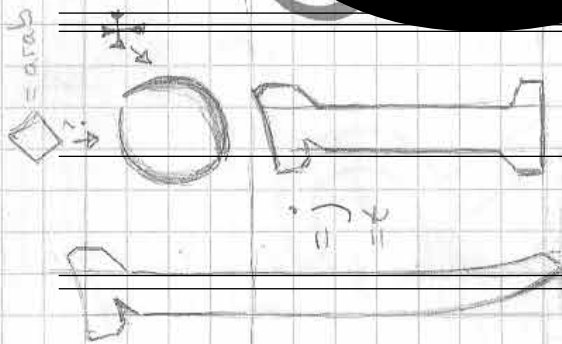
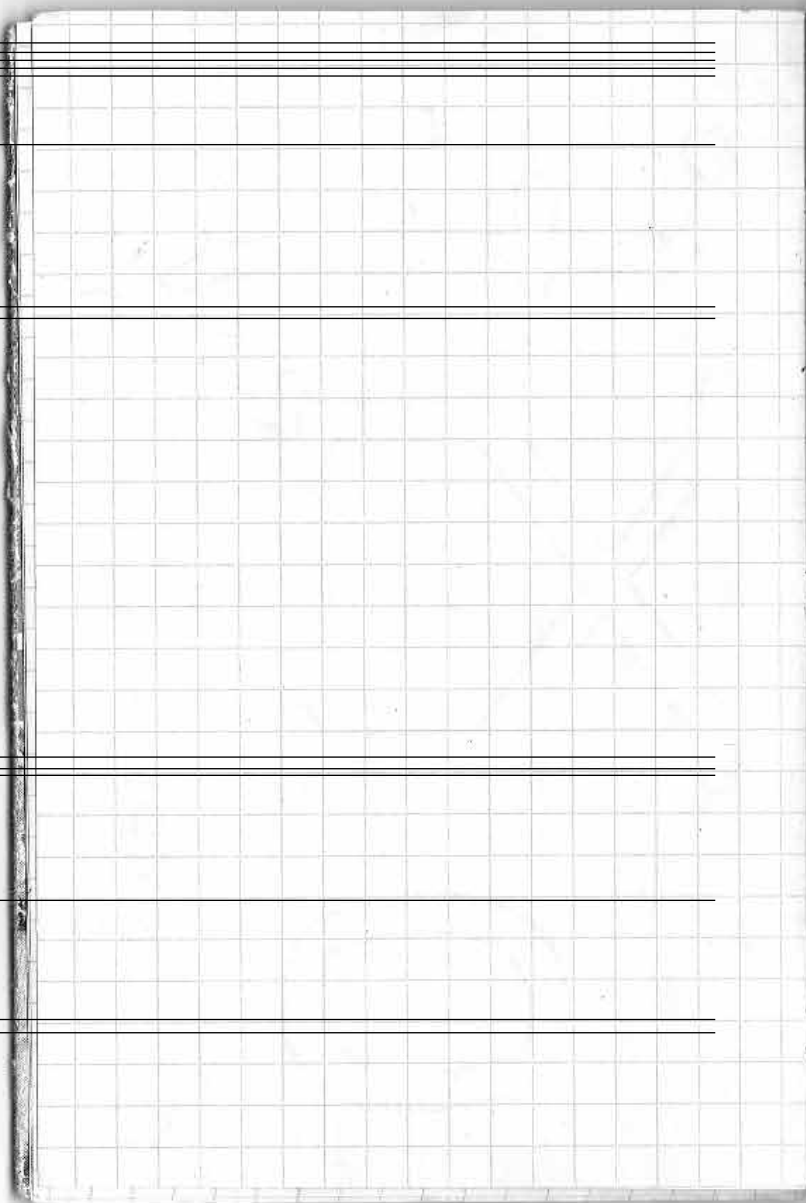

zyxwvkr
m q cd

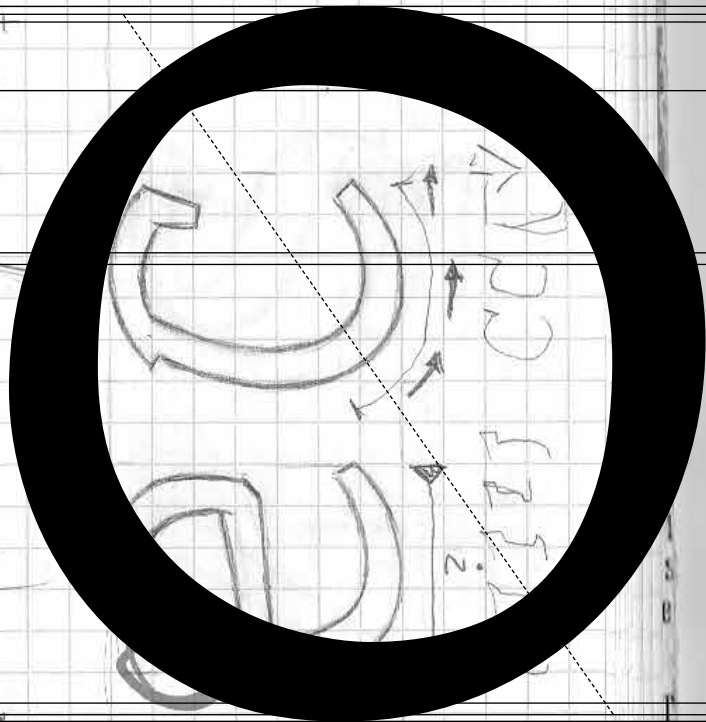

A B C D E F G H I

a b c d e f g h i j k l m

J K L M N O P Q

n o p q r s t u v w x y z

R S T U V W X Y Z

»

Vaters

›ZOO‹

Anzug

«

„Vaters

‘Zoo’

Anzug“

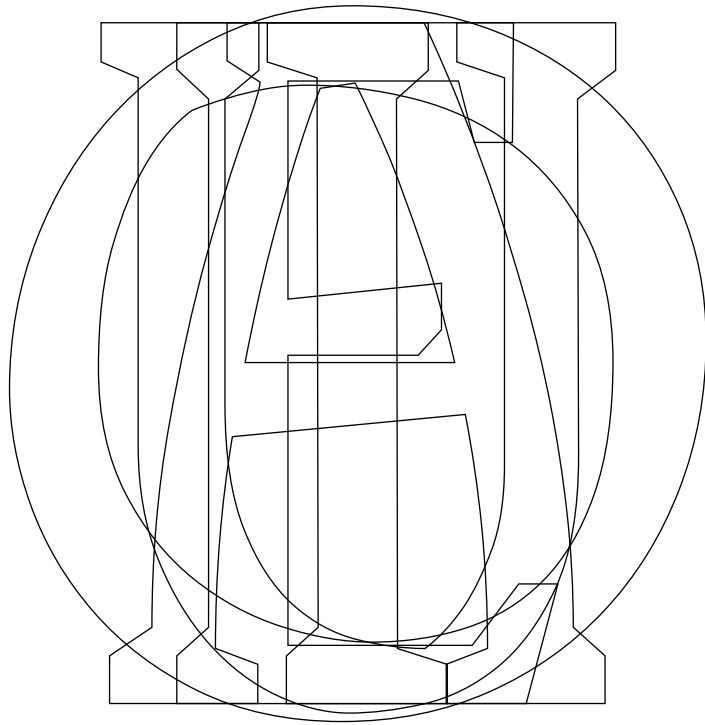

À É Í Ò Û

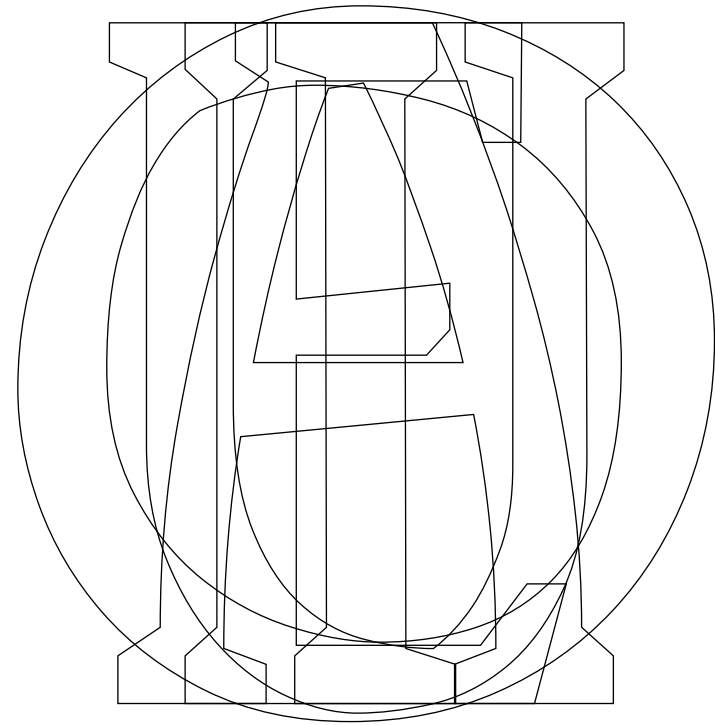

À É Í Ò Û

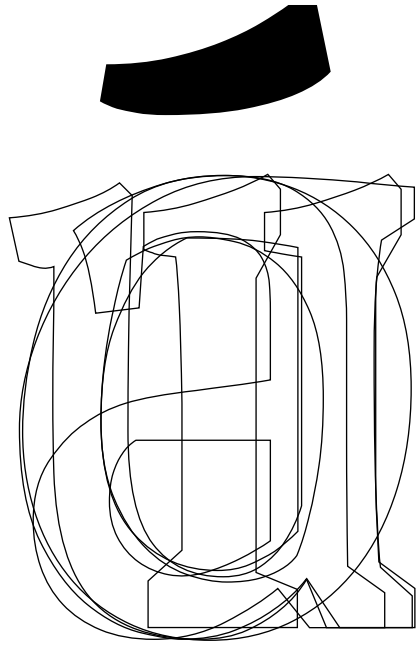

ā á ē í ò ũ

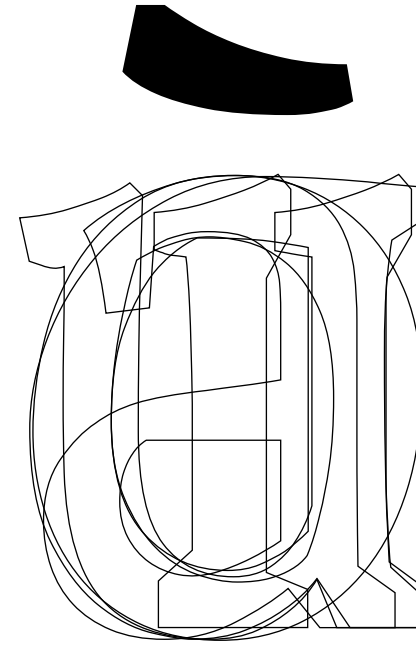

ã ä ë ï ò ũ

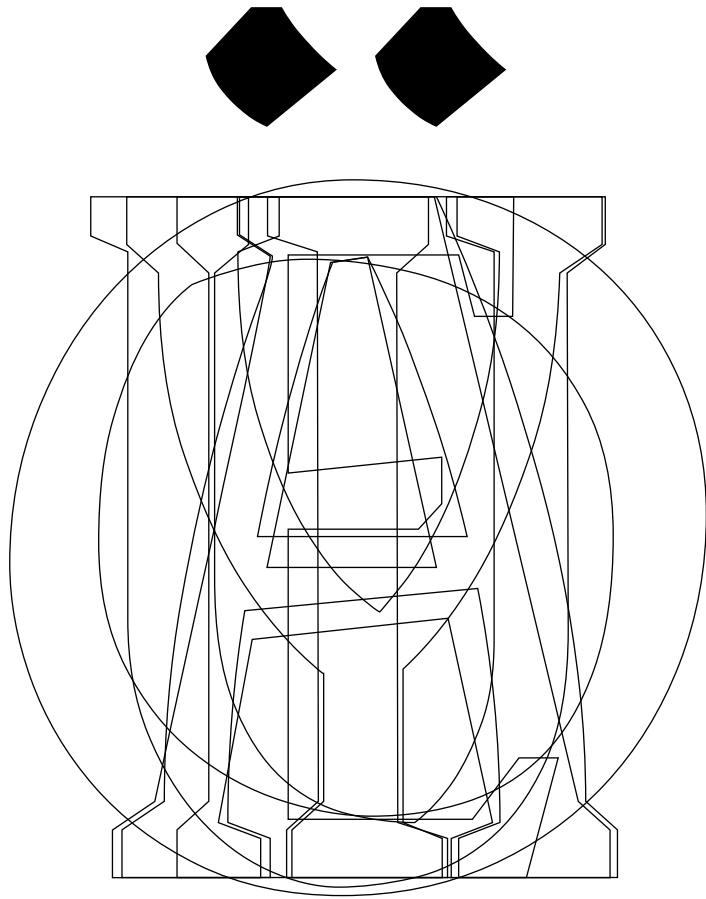

Ä Ę Ĩ Ö Ü Ÿ

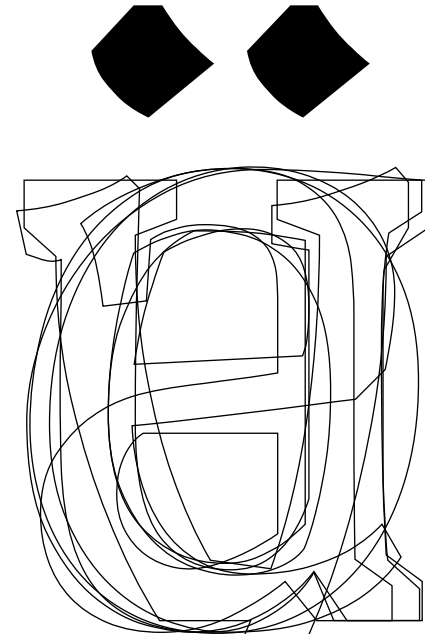

ä ę ĩ ö ü Ÿ

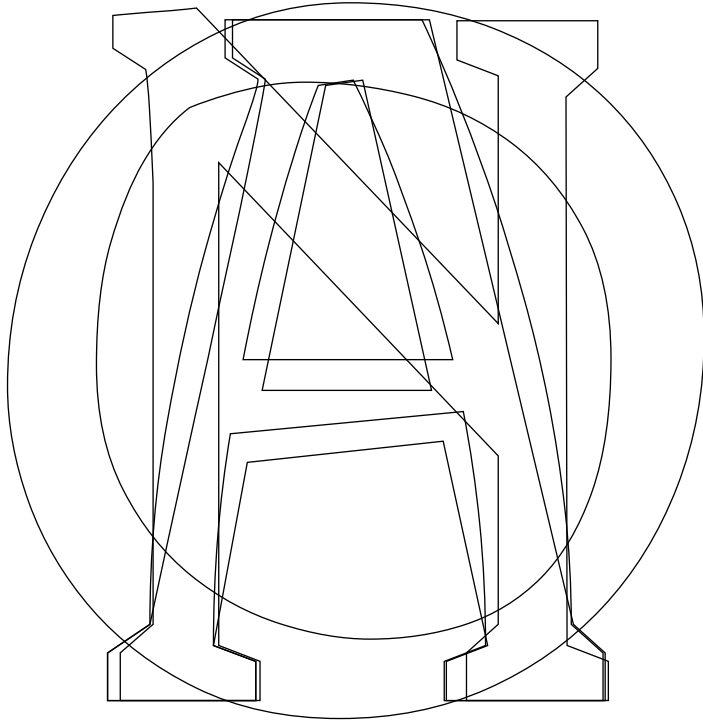

Ã Ä Ñ Õ

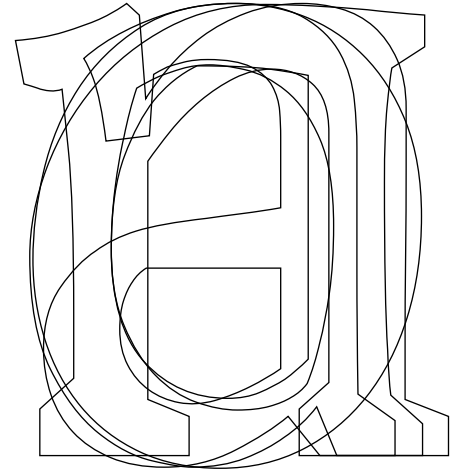

ã ä ñ õ

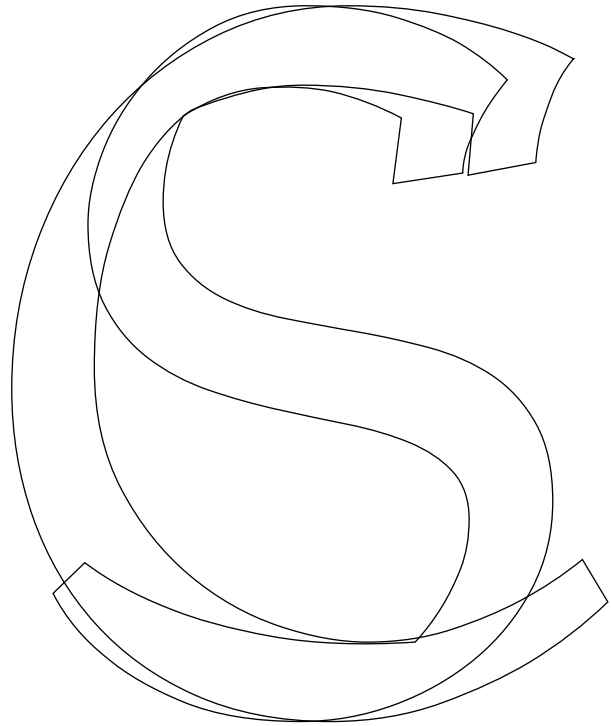

ç



s

• LANGUAGE SUPPORT •

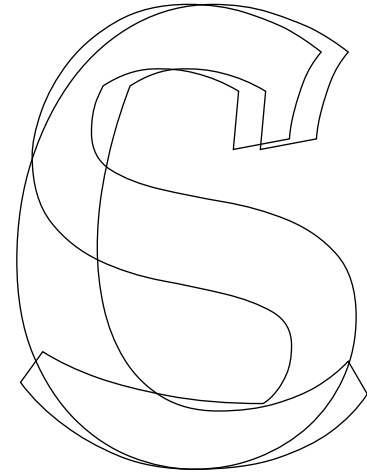

ç



s

• LANGUAGE SUPPORT •

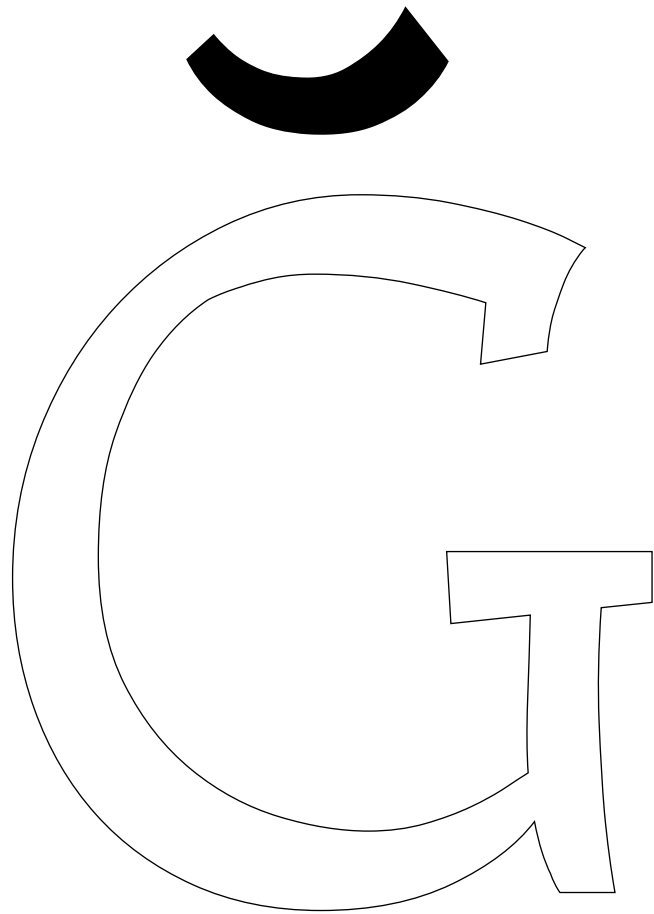

Ĝ

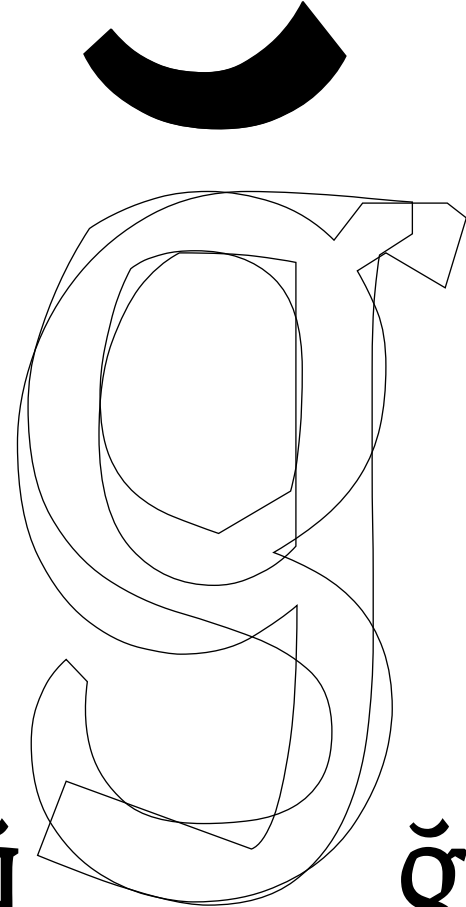

ŝ

ŝ

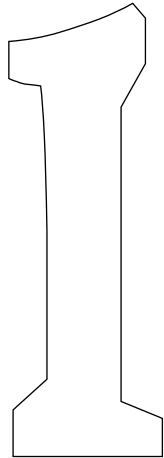

I

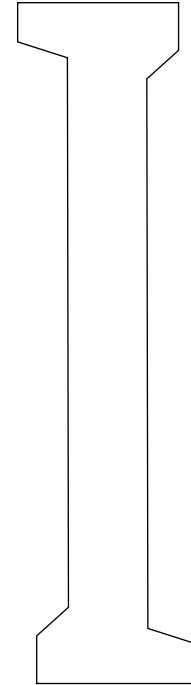
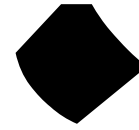

i

10 pt / 12, 5 pt

< 35 >

Maio. Magnit qam voliorum quoditaqui aut dendilta temporum lab ium quae. Et lautassit ut peratiatur? Pe quiam, sentis remporum fugia nonsequia num veles at apiciae volorum quatur, quatur magnaturio te eos ulleseque solum dolorro ium ne aperspeidit, endenet aut quatis as aut quia asp sandebis ut omnimus et laut exernaturis sanis milit pel iligent audit am init is sec la peri cus arcimet lat as endit et restis duscitia dolupti dic te quoditiae. Itate none eatium seque velit laut aliquis explia cor aliqui to quati officaectota cuptatus essunti bernam aut ex esed excesti busciendit labores ataqubus ea corerspedis eaqui corepti nihillaut id quis diam, sam que iusto earuntis atet, opta pra vid magnis sinctur sundest iaspid este osandandem quides plabore hendaepudit, quidebis dolupta tiani descipsunt voluptia verovid quis ipsae nam, nescienis samenduci as adione ex earunto eici mus repudam, ut lant.

Itatemquis volectem ex eicil ipsa volorum ape rum ulpa ab ium invol ide et laboribeatis dolupte ommodis et ex ea aut eossi volum evelentione nulluptia inum, volum quatiscia volestotatur ide archilla explab idunt. Olorumquia qui delectae. Luptatio mi, uta dolut la voloris et voluptat autom ommissin ea pariatum rem rerspiducid estisci.

10 pt / 12, 5 pt

< 35 >

Maio. Magnit qam voliorum quoditaqui aut dendilta temporum lab ium quae. Et lautassit ut peratiatur? Pesiste quiam, sentis remporum fugia nonsequia num veles at apiciaste volorum quatur, quaturam et magnaturio te eos ulleseque solum dolorro ium ne aperspeidit, endein asnet aut quatis as aut quia asp sandebis ut omnimus et laut exernaturis sanis milit pel iligent audit am init is sec la peri cus arcimet lat as endit et restis duscitia dolupti dic te quoditiae. Itate none eatium seque velit laut aliquis explia cor aliqui to quati officaectota laut cuptatus essunti bernam aut ex esed excesti busciendit labores ataqubus ea corerspedis eaqui corepti nihillaut id quis diam, sam que iusto earuntis atetist, alopta pra vid magnis sinctur sundest iaspid este osandandem quides plabore hendaepudit, quidebis dolupta pra vid tiani descipsunt voluptia verovid quis ipsae nam, nescienis samenduci as adione ex earunto eici mus repudam, ut lant.

Itatemquis volectem ex eicil ipsa volorum apelupti rum ulpa ab ium invol ide et laboribeatis dolupte ommodis et ex ea aut eossi volum evelentione nulluptia inum, volum quatiscia incir volestotatur ide archilla explab idunt. Olorumquia estem qui delectae. Luptatio mi, uta dolut la voloris et voluptat autom ommissin ea pariatum rem rerspiducid estisci.

Lorem ipsum dolor sit amet, consetetur sadipscing elitr, sed diam nonumy eirmod tempor invidunt ut labore et dolore magna aliquyam erat, sed diam voluptua. At vero eos et accusam et justo duo dolores et ea rebum. Stet clita kasd gubergren, no sea takimata sanctus est Lorem ipsum dolor sit amet. Lorem ipsum dolor sit amet, consetetur sadipscing elitr, sed diam nonumy eirmod tempor invidunt ut labore et dolore magna aliquyam erat, sed diam voluptua. At vero eos et accusam et justo duo dolores et ea rebum. Stet clita kasd gubergren, no sea takimata sanctus est Lorem ipsum dolor sit amet. Agnimi, se ipsus moditat qui dolestiur, conseditius am simaxim enduntis ad et aut volorum fugitatum arum eaquo omnim liquas ma dolorrora dolum utatus eat fugitia testist evelit odigentia quunt quo officius audae lant dolorem que pratusdam facias apercienture.

Lorem ipsum dolor sit amet, consetetur sadipscing elitr, sed diam nonumy eirmod tempor invidunt ut labore et dolore magna aliquyam erat, sed diam voluptua. At vero eos et accusam et justo duo dolores et ea rebum. Stet clita kasd gubergren, no sea takimata sanctus est Lorem ipsum dolor sit amet. Lorem ipsum dolor sit amet, elitr consetetur sadipscing, sed diam nonumy eirmod tempor invidunt ut labore et dolore magna amet aliquyam erat, sed diam. At voluptua verost eos et accusam et justo duo et enan dolores rebum. Stet clita kasd gubergren, no sea takimata sanctus est Lorem ipsum dolor sit moditat amet. Agnimi, seka ipsus qui dolestiur, Conseditius anro am simaxim enduntis ad etimt aut volorr umfugitatum orimnim arum eaquo liquas ma dolorrora dolum utatus eat fugitia testist evelit odigentia quunt quo audae officius lant pratusdam dolorem que facias apercienture.

• , : ; ! ?

“ ” , „ < > « »

” ’ ° @ / \ • •

• • • — — — — —

Simon Slegers

Yazı Karakteri Tasarımı
2012 – 2013 Güz

Mimar Sinan
Güzel Sanatlar Üniversitesi
İstanbul

University of
Applied Sciences Münster
Germany

s.slegers@gmail.com

2

2012 – 2013

0

Mimar Sinan

1

Güzel Sanatlar Üniversitesi

2

İstanbul

T Ü R K E Y

—

University of

Applied Sciences Münster

1

G E R M A N Y

3